

WIRING LEGEND

RED 14 AWG - FILTERED POSITIVE, HTR & MON. B+
 WHITE 22 AWG - REF. FAN
 VIOLET 14 AWG - PUMP
 GREY1 22 AWG- GREY TANK
 BLACK 22 AWG- GREY2 TANK
 BROWN 22 AWG - HOLDING
 ORANGE 22 AWG - LPG
 BLUE 22 AWG - FRESH TANK
 GREY 20 AWG - HEATER IGNITION
 PINK 20 AWG - HEATER FAULT
 GREEN 20 AWG - ELECTRIC HEATER

REPLACEMENT PARTS

PRINTED CIRCUIT BOARD - # SUBPCBM29
 PUMP AND HEATER SWITCHES-# SWOKLED1
 RESISTOR PIGTAIL - # K101

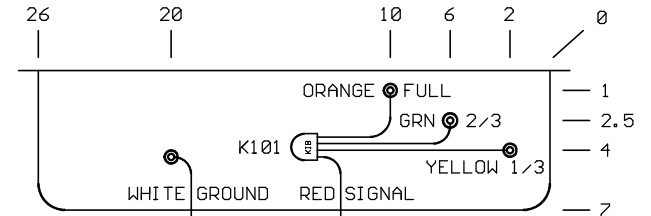
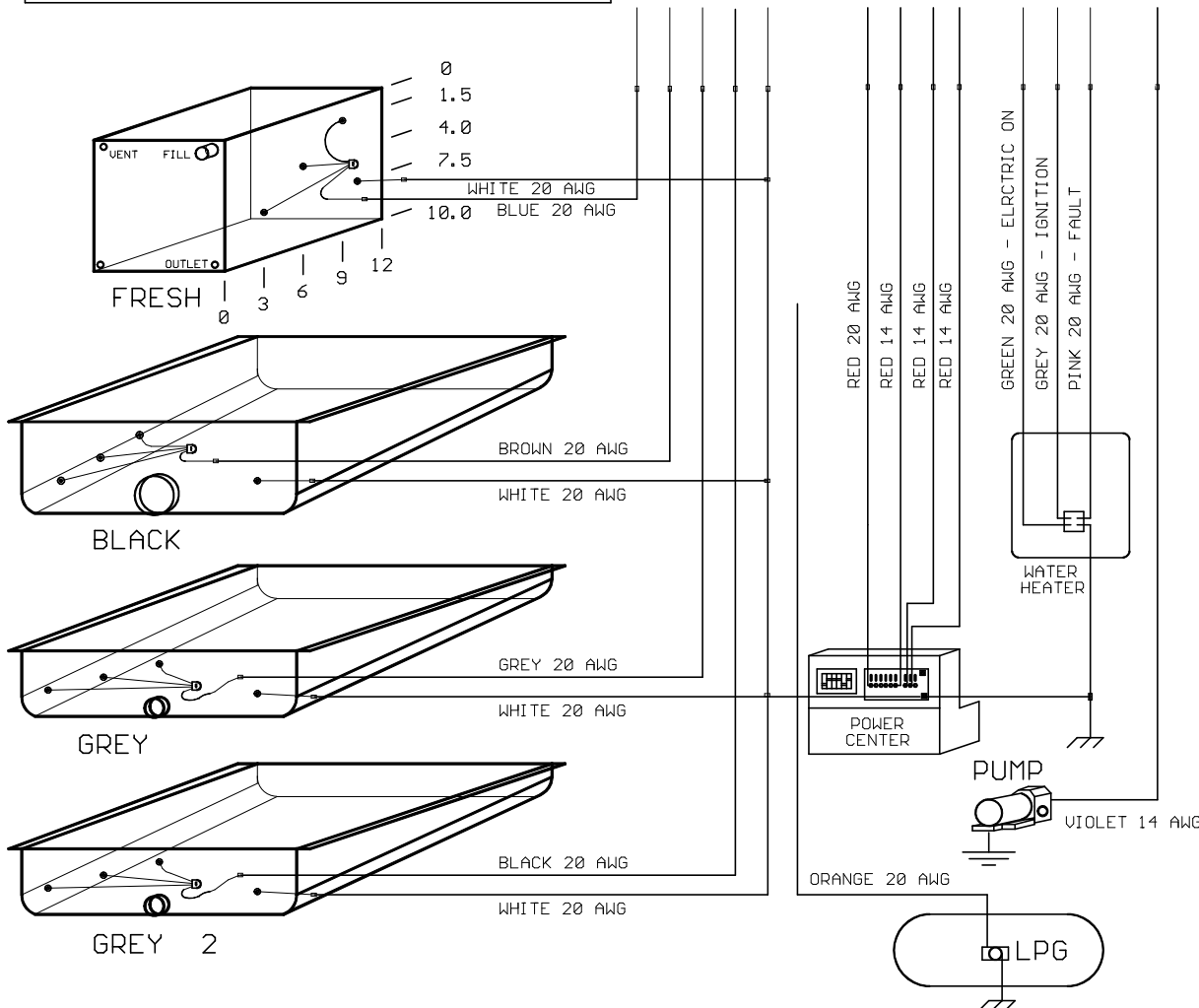
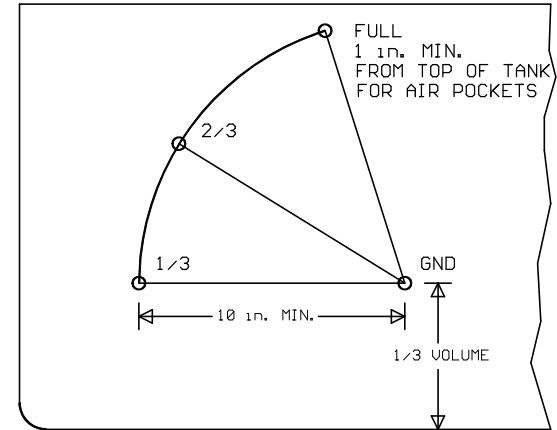
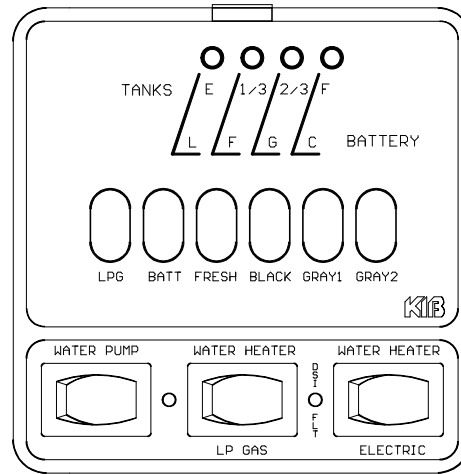

PLACE 1/3 AND GROUND INSERT AT 1/3 VOLUME.
 PLACE GROUND INSERT NO LESS THAN 10 in. FROM OTHER INSERTS IN HOLDING AND GREY TANKS. USE ALL AVAILABLE SPACE.
 ALL HOLDING & LPG TANK GROUNDS MUST BE ATTACHED TO MONITOR GROUND.

MP1 PROBE INSTALLATION

MARK TANK PER PLACEMENT GUIDE.
 DRILL HOLES USING 3/8 in. BIT. DRILL AT LOW SPEED.
 INSERT MP1 INTO HOLE
 REMOVE TOP 3/8 in NUT
 TIGHTEN BOTTOM NUT UNTIL SNUG, DO NOT OVER TIGHTEN
 * USE NUT DRIVER, DO NOT USE SCREW GUN
 ATTACH WIRE WITH NUT REMOVED EARLIER
 SEAL EXPOSED CONNECTIONS WITH RED BATTERY SPRAY OR SILICON SEALER

KIB enterprises corp.	
TITLE: M26-2-L WIRING DIAGRAM	
DRAWN BY : W.F.Faubion	REV: A
DATE: 9/6/2003	SHEET: 1/1