

### WIRING LEGEND

RED 14 AWG - FILTERED POSITIVE, HTR & MON. B+  
 WHITE 22 AWG - REF. FAN  
 VIOLET 14 AWG - PUMP  
 GREY 22 AWG- GREY TANK  
 BROWN 22 AWG - HOLDING  
 BLUE 22 AWG - FRESH TANK  
 GREY 20 AWG - HEATER IGNITION  
 PINK 20 AWG - HEATER FAULT  
 GREEN 20 AWG - ELECTRIC HEATER

### REPLACEMENT PARTS

PRINTED CIRCUIT BOARD - # SUBPCBM21  
 PUMP AND HEATER SWITCHES-# SWOKLED1  
 RESISTOR PIGTAIL - # K101

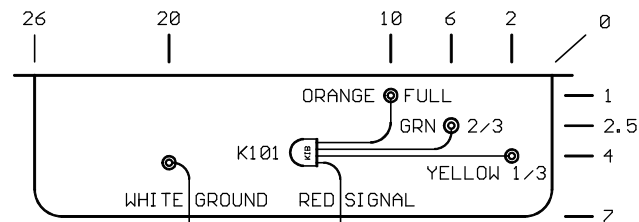
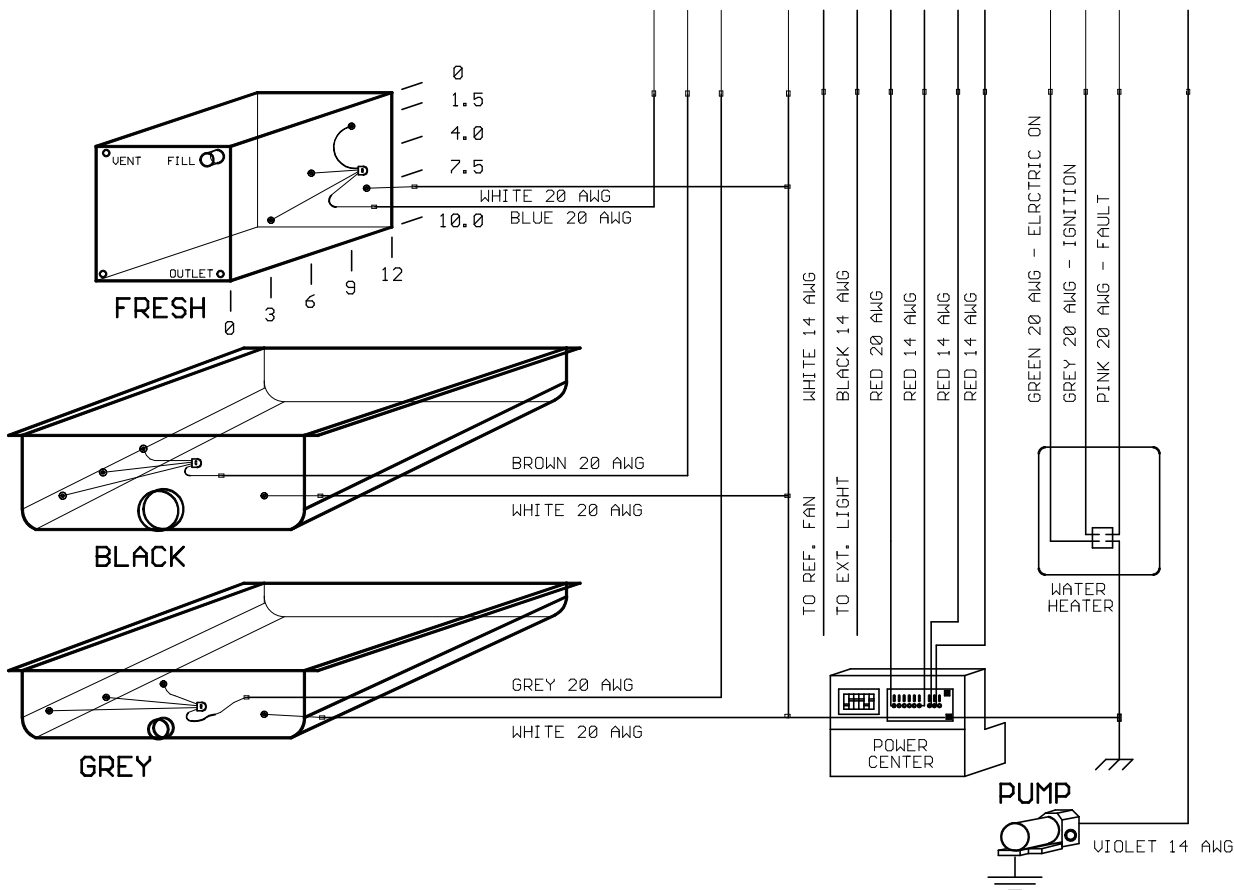
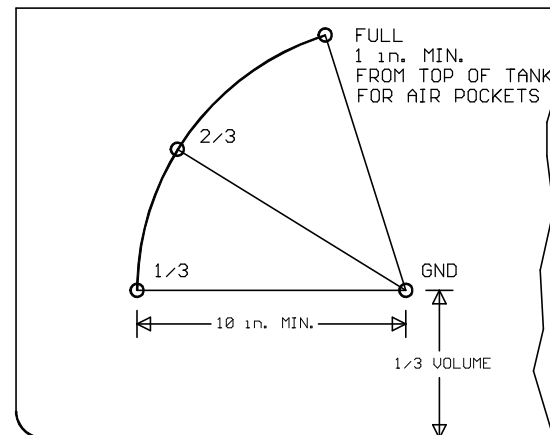
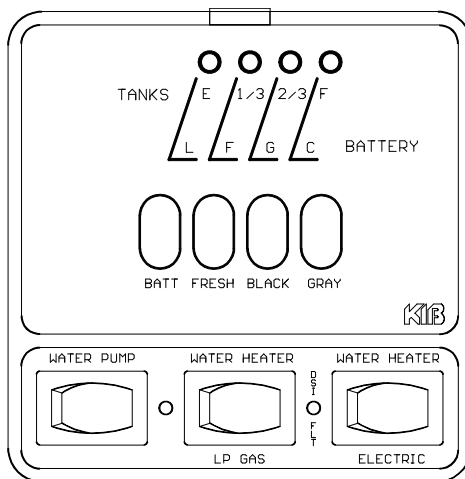

PLACE 1/3 AND GROUND INSERT AT 1/3 VOLUME.

PLACE GROUND INSERT NO LESS THAN 10 in. FROM OTHER INSERTS IN HOLDING AND GREY TANKS. USE ALL AVAILABLE SPACE.

ALL HOLDING & LPG TANK GROUNDS MUST BE ATTACHED TO MONITOR GROUND.

### MP1 PROBE INSTALLATION

MARK TANK PER PLACEMENT GUIDE.  
 DRILL HOLES USING 3/8 in. BIT. DRILL AT LOW SPEED.  
 INSERT MP1 INTO HOLE  
 REMOVE TOP 3/8 in NUT  
 TIGHTEN BOTTOM NUT UNTIL SNUG, DO NOT OVER TIGHTEN  
 \* USE NUT DRIVER, DO NOT USE SCREW GUN  
 ATTACH WIRE WITH NUT REMOVED EARLIER  
 SEAL EXPOSED CONNECTIONS WITH RED BATTERY SPRAY OR SILICON SEALER

<b>KIB</b> enterprises corp.	
TITLE: M23-2-L WIRING DIAGRAM	
DRAWN BY : W.F.Faubion	REV: A
DATE: 9/6/2003	SHEET: 1/1