

M21NP WIRING LEGEND

RED - FILTERED POSITIVE
 WHITE - GROUND
 GREY - GREY TANK
 BROWN - HOLDING TANK
 BLUE - FRESH TANK

REPLACEMENT PARTS

PRINTED CIRCUIT BOARD - # SUBPCBM21
 RESISTOR PIGTAIL - # K101

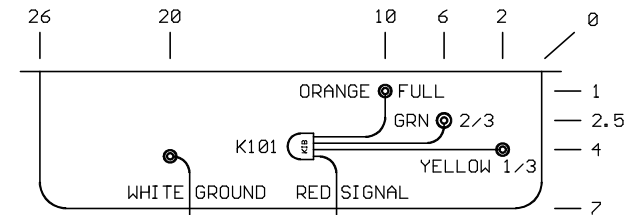
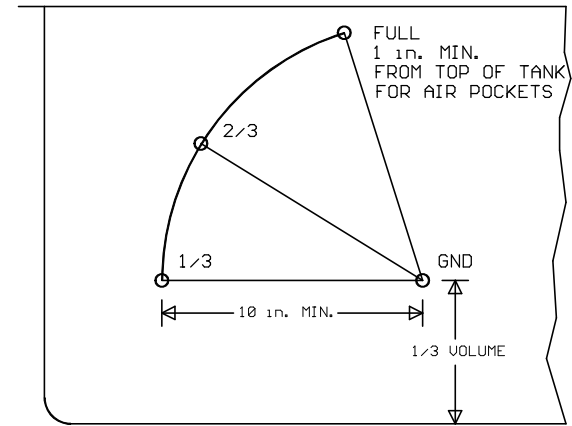
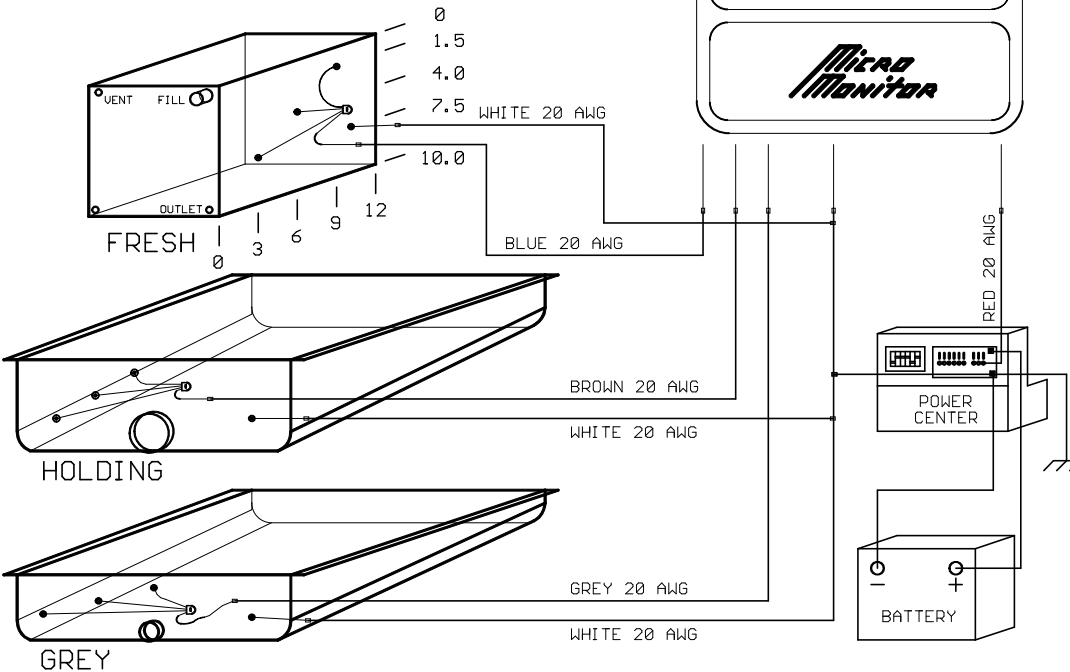
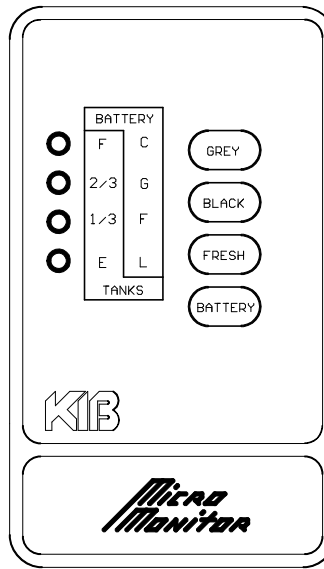

PLACE 1/3 AND GROUND INSERT AT 1/3 VOLUME.

PLACE GROUND INSERT NO LESS THAN 10 in. FROM OTHER INSERTS IN HOLDING AND GREY TANKS. USE ALL AVAILABLE SPACE.

ALL HOLDING & LPG TANK GROUNDS MUST BE ATTACHED TO MONITOR GROUND.

MP1 PROBE INSTALLATION

MARK TANK PER PLACEMENT GUIDE.
 DRILL HOLES USING 3/8 in. BIT. DRILL AT LOW SPEED.
 INSERT MP1 INTO HOLE
 REMOVE TOP 3/8 in NUT
 TIGHTEN BOTTOM NUT UNTIL SNUG, DO NOT OVER TIGHTEN
 * USE NUT DRIVER, DO NOT USE SCREW GUN
 ATTACH WIRE WITH NUT REMOVED EARLIER
 SEAL EXPOSED CONNECTIONS WITH RED BATTERY SPRAY OR SILICON SEALER