

K21X2 WIRING LEGEND

RED 22 AWG - FILTERED POSITIVE
 RED 14 AWG - POSITIVE UDC PUMP
 VIOLET 14 AWG - PUMP
 WHITE - GROUND
 BROWN - HOLDING 1 TANK
 YELLOW - HOLDING 2 TANK
 BLUE - FRESH TANK
 GREY - GREY 1 TANK
 BLACK - GREY 2 TANK

REPLACEMENT PARTS

PRINTED CIRCUIT BOARD - # SUBPCBK21
 PUMP SWITCH - # SWOKLED1
 TEST SWITCH - # SWMOMK1
 BATH SWITCH - # SWE2-41
 RESISTOR PIGTAIL - # K101

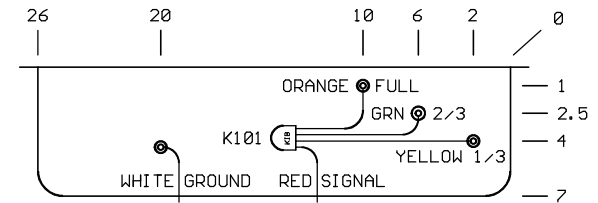
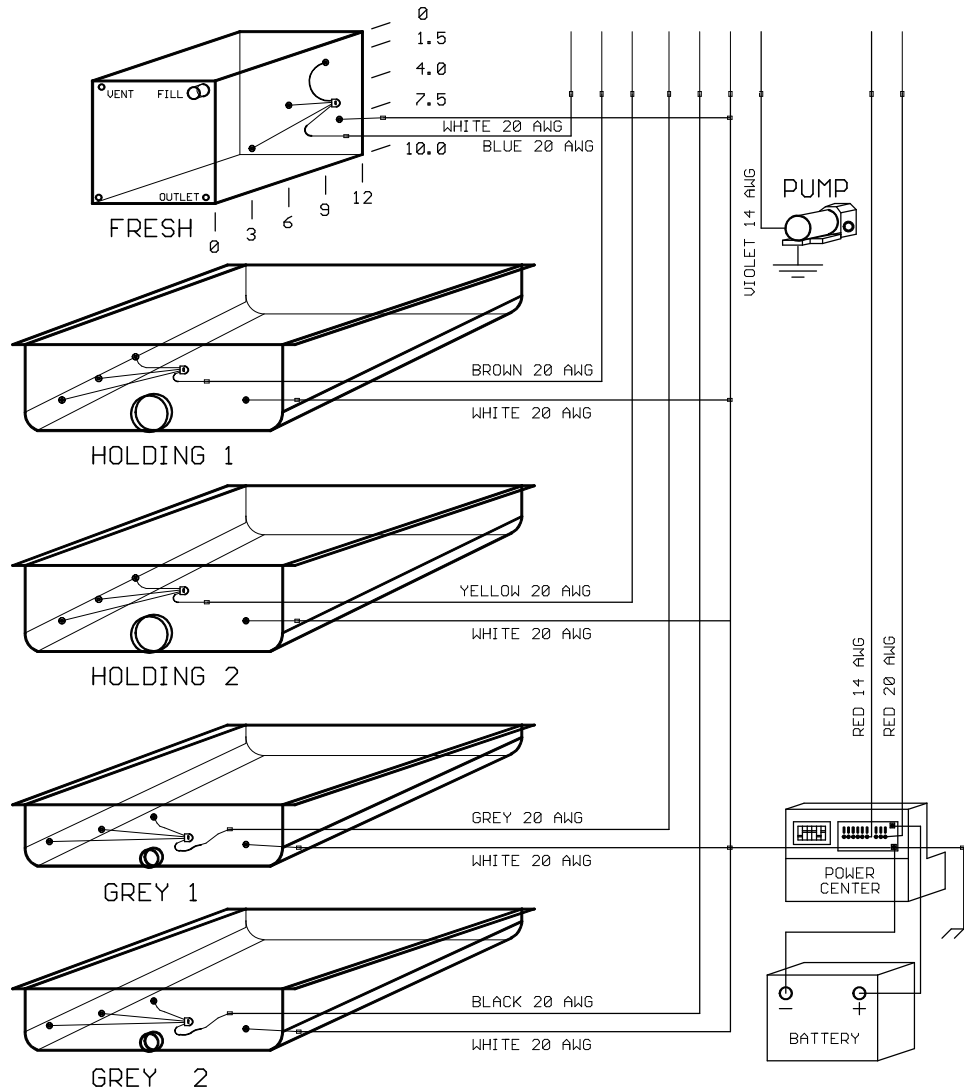
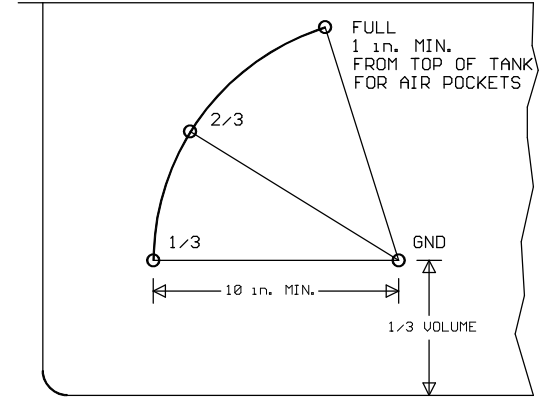
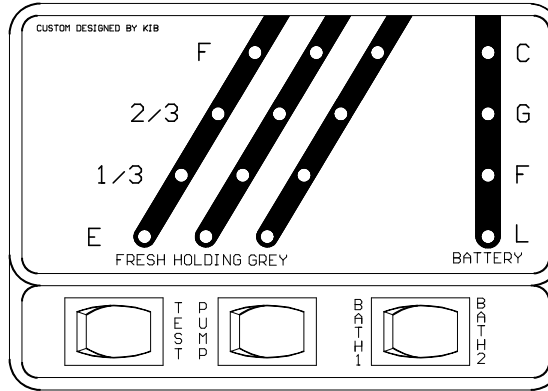

PLACE 1/3 AND GROUND INSERT AT 1/3 VOLUME.

PLACE GROUND INSERT NO LESS THAN 10 in. FROM OTHER INSERTS IN HOLDING AND GREY TANKS. USE ALL AVAILABLE SPACE.

ALL HOLDING & LPG TANK GROUNDS MUST BE ATTACHED TO MONITOR GROUND.

MP5 PROBE INSTALLATION

MARK TANK PER PLACEMENT GUIDE.
 DRILL HOLES USING 3/8 in. BIT. DRILL AT LOW SPEED.
 INSERT MP1 INTO HOLE
 REMOVE TOP 3/8 in NUT
 TIGHTEN BOTTOM NUT UNTIL SNUG, DO NOT OVER TIGHTEN
 * USE NUT DRIVER, DO NOT USE SCREW GUN
 ATTACH WIRE WITH NUT REMOVED EARLIER
 SEAL EXPOSED CONNECTIONS WITH RED BATTERY SPRAY OR SILICON SEALER

KIB enterprises corp.	
TITLE: K21X2 WIRING DIAGRAM	
DRAWN BY: W.F.Faubion	REV: A
DATE: 6/25/99	SHEET: 1/1